

LC Sine Wave Filter for Motor Drives

勝特力材料 886-3-5753170
 勝特力电子(上海) 86-21-34970699
 勝特力电子(深圳) 86-755-83298787
[Http://www.100y.com.tw](http://www.100y.com.tw)



- Smooth sine wave without voltage peaks
- Perfect motor protection
- Reduce bearing currents
- Motor frequency up to 200 Hz
- Extended motor cable length capability



Performance indicators

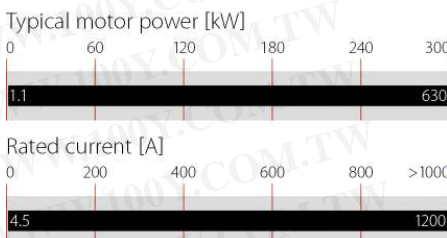

Approvals



UL508C up to 260 A. For use with AC or DC drives (power conversion equipment) only

Features and benefits

- Converts the rectangular PWM output voltage of motor drives into a smooth sine wave with low residual ripple
- Elimination of premature motor damage caused by high dv/dt, overvoltages, cable ringing, motor overheating, and eddy current losses
- Improves bearing life time because of bearing currents caused by circulating currents
- Complies with IEC 60034-17* and NEMA-MG1 requirements for general purpose motors
- Optional with NEMA 1 protective cover

Technical specifications

Approvals	UL 508 pending
Declaration of conformity	CE / LVD
Design corresponding to	IEC 61558-2-20
Environmental reliability	IEC 60068-2-1
Flammability corresponding to	UL 94 V-2 or better
High potential test voltage	P → E 3000 VAC, 1 minute P → P 2500 VAC, 1 minute
Impedance (uk)	8 to 10% @ 400 V, 50 Hz and rated current
Insulation class	EIS 200
Max. operating voltage	3x 500 VAC + 10%
Motor cable length	Up to 2,000 m (see graph)
Motor frequency	70 Hz (up to 200Hz with derating (see graph))
MTBF 1	>100,000 hours
Overload capability	1.5x rated current for 1 minute, once per hour
Protection category	IP00 (FN 5040) IP20 (FN 5045)
Rated currents	4.5 to 1200 A @ 45 °C max.
Residual ripple voltage	<5%
Switching frequency	See filter selection table
Temperature range (operation and storage)	- 25 °C to +70 °C (25/070/21)



Typical applications

- HVAC applications
- Pumps
- Ventilators
- Conveyors
- Compressors
- Elevators
- Cranes
- Medium voltage applications, deployed in front of the step-up transformer
- Retrofit installations with motor drives
- Motor drive with long motor cable
- Motor drive with multiple motors in parallel

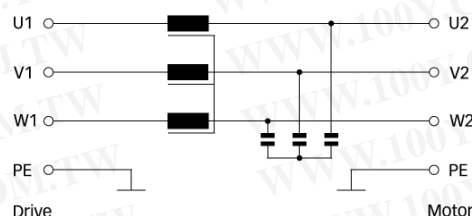
Typical electrical schematic



Filter selection table

Filter	Rated current @ 45 °C/50 Hz	Rated current @ 45 °C/100 Hz	* Typical motor drive rating	Nominal inductance	Nominal capacitance	Capacitance connection	Min. switching frequency	** Typical power loss	Input/Output connections	Weight
	[A]	[A]	[kW]	[mH]	[µF]		[kHz]	[W]	 	[kg]
FN 5040-4.5-82	4.5	4.05	1.1/1.5	13	2.2	Y	4	65	-82	3.3
FN 5040-8-82	8	7.2	2.2/3	6.9	4.7	Y	4	80	-82	4.6
FN 5040-10-83	10	9	4	5.2	6.8	Y	4	90	-83	6.1
FN 5040-17-83	17	15.3	5.5/7.5	3.1	10	Y	4	115	-83	7.8
FN 5040-24-84	24	21.6	11	2.4	10	Y	4	150	-84	14.4
FN 5040-38-84	38	34.2	15/18.5	1.6	10	Y	4	170	-84	25.0
FN 5040-48-85	48	43.2	22	1.1	14.7	Y	4	260	-85	33.0
FN 5040-62-86	62	55.8	30	0.85	30	Y	3	280	-86	36.0
FN 5040-75-87	75	67.5	37	0.75	30	Y	3	330	-87	42.0
FN 5040-115-87	115	103.5	45/55	0.5	20	Δ	3	500	-87	68.0
FN 5040-180-99	180	162	75/90	0.3	33	Δ	3	680	-99	86.0
FN 5040-260-99	260	234	110/132	0.2	47	Δ	3	880	-99	125.0
FN 5040-410-99	410	369	160/200	0.13	66	Δ	3	1100	-99	184.0
FN 5040-480-99	480	432	250	0.11	94	Δ	3	1350	-99	235.0
FN 5040-660-99	660	594	315/355	0.14	141	Δ	2	2000	-99	310.0
FN 5040-750-99	750	675	400	0.12	165	Δ	2	2800	-99	470.0
FN 5040-880-99	880	792	400/500	0.11	188	Δ	2	3400	-99	640.0
FN 5040-1200-99	1200	1080	560/630	0.075	282	Δ	2	3800	-99	680.0
FN 5045-4.5-44	4.5	4.05	1.1/1.5	13	2.2	Y	4	65	-44	4.1
FN 5045-8-44	8	7.2	2.2/3	6.9	4.7	Y	4	80	-44	5.4
FN 5045-10-44	10	9	4	5.2	6.8	Y	4	90	-44	6.9
FN 5045-17-33	17	15.3	5.5/7.5	3.1	10	Y	4	115	-33	9.0
FN 5045-24-33	24	21.6	11	2.4	10	Y	4	150	-33	15.6
FN 5045-38-33	38	34.2	15/18.5	1.6	10	Y	4	170	-33	18.9
FN 5045-48-34	48	43.2	22	1.1	14.7	Y	4	260	-34	35.8
FN 5045-62-34	62	55.8	30	0.85	30	Y	3	280	-34	37.8
FN 5045-75-35	75	67.5	37	0.75	30	Y	3	330	-35	60.0
FN 5045-115-35	115	103.5	45/55	0.5	20	Δ	3	500	-35	70.0
FN 5045-180-99	180	162	75/90	0.3	33	Δ	3	680	-99	92.0
FN 5045-260-99	260	234	110/132	0.2	47	Δ	3	880	-99	131.0
FN 5045-410-99	410	369	160/200	0.13	66	Δ	3	1100	-99	198.0
FN 5045-480-99	480	432	250	0.11	94	Δ	3	1350	-99	243.0
FN 5045-660-99	660	594	315/355	0.14	141	Δ	2	2000	-99	425.0
FN 5045-750-99	750	675	400	0.12	165	Δ	2	2800	-99	482.0
FN 5045-880-99	880	792	400/500	0.11	188	Δ	2	3400	-99	652.0
FN 5045-1200-99	1200	1080	560/630	0.075	282	Δ	2	3800	-99	692.0

* General purpose four-pole (1500 r/min) AC induction motor rated 400 V/50 Hz.

** Exact value depends upon the motor cable type and length, switching frequency, motor frequency and further stray parameters within the system.

Installation

Filter placement

Lift the filter with appropriate crane using lifting eye bolts – smaller types may be lifted manually by two persons (no lifting eye bolt applicable).

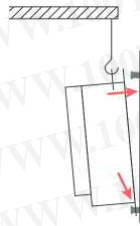

Wiring and connection

The filter rating has to be compatible with the inverter to which it is to be connected. All inverter manufacturer installation and safety instructions must be fulfilled. The typical block schematic is shown for a motor load but the load can be also multiple motors or a transformer. Inverter and load cable selection/placement should be in accordance with all local electrical standards and regulations. Filters with separate capacitor bank must be connected as follows:

Required settings

Ensure the drive's switching frequency is set to the required minimum switching frequency (see filter selection table). Higher frequencies are allowed. The mode of operation must be "scalar" (V/Hz). Check the inverter manual whether special settings are necessary. In any doubt contact the inverter manufacturer.

CAUTION: If the inverter settings are not in accordance the filter may be damaged.

Never attempt to handle the filter with a forklift!



In order to ensure sufficient air flow, keep a distance of 150 mm above and below the filter to walls or other components. A 20 mm distance on either side is recommended.

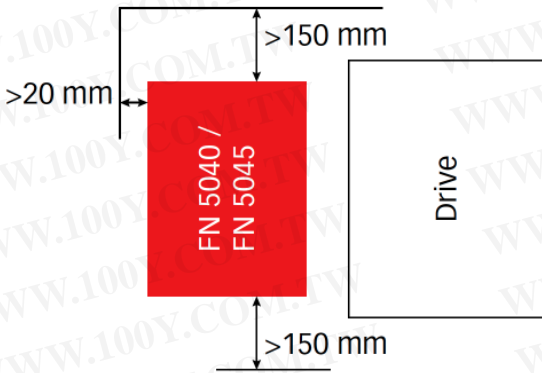
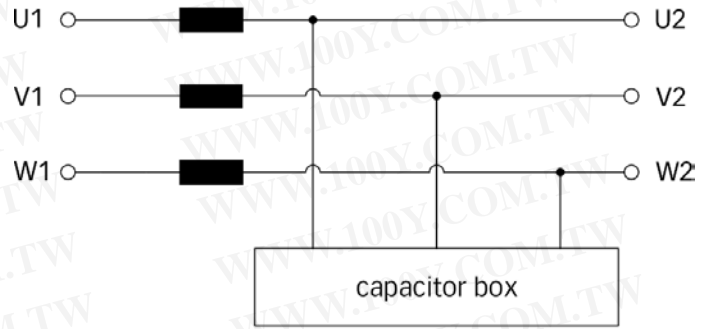

Typical block schematic

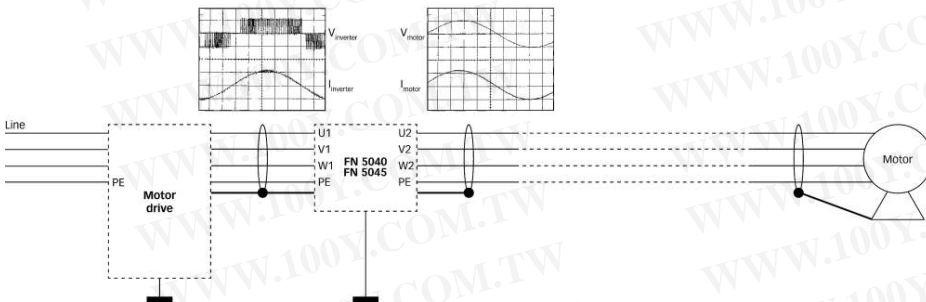

Motor frequency derating

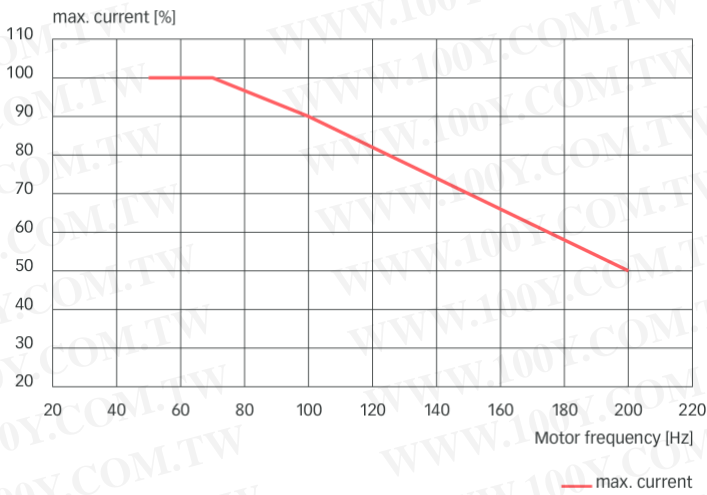

Max. motor cable length

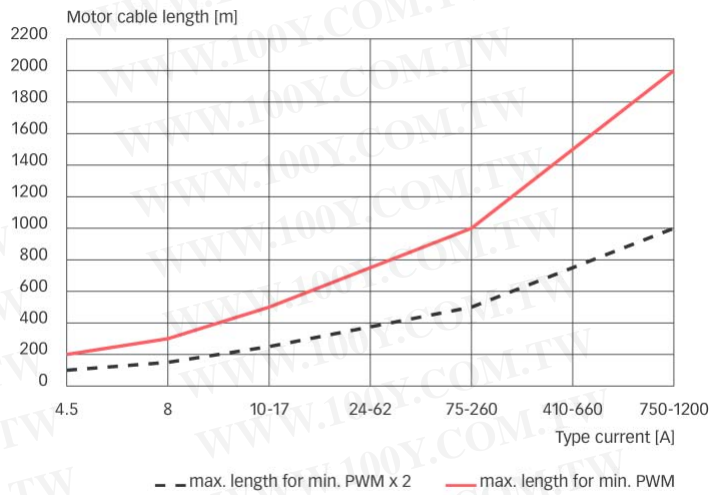

Mechanical data FN 5040

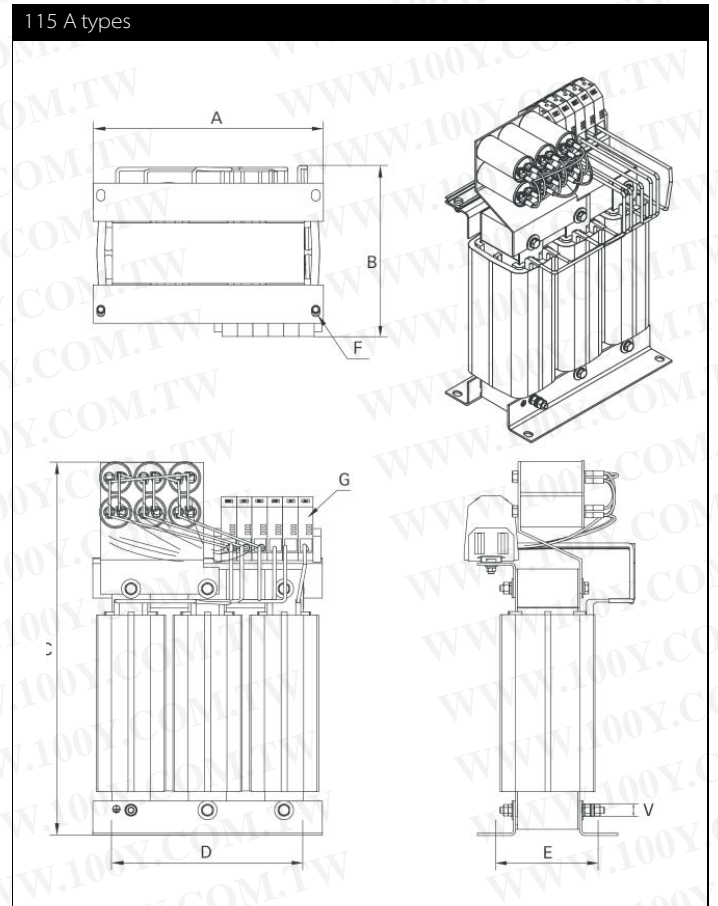
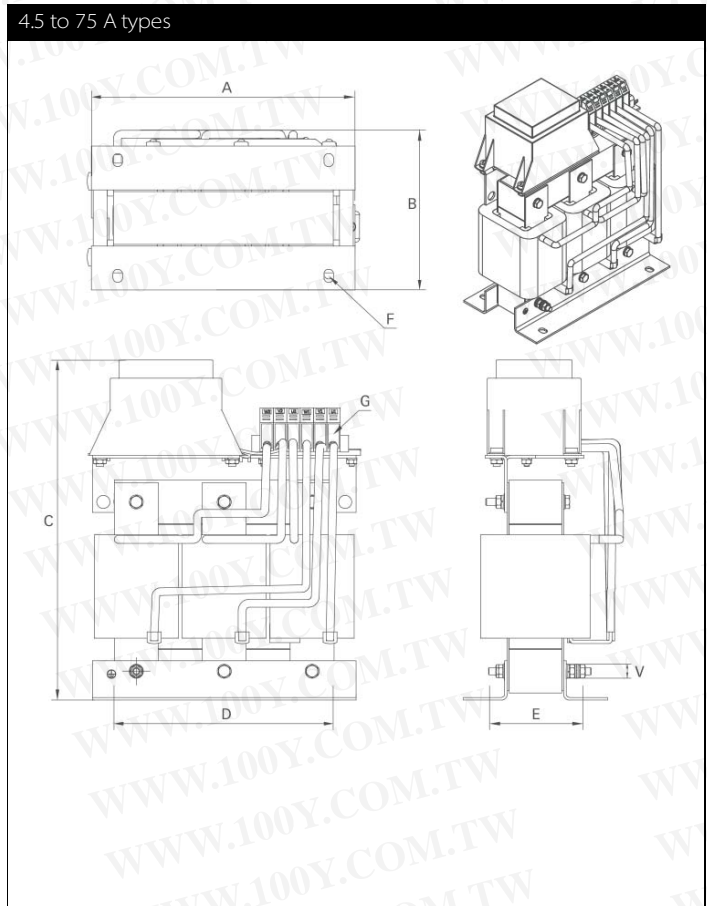

180 to 1200 A types*

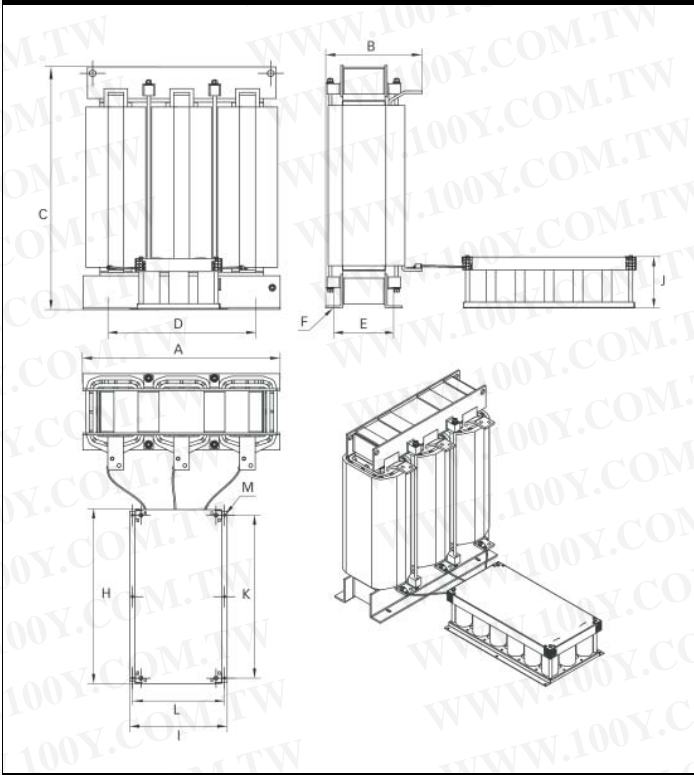

Cable length of capacitor box:

180 to 410 A = 1000 mm

480A to 1200 A = 1500 mm

Dimensions FN 5040

	4.5 A	8 A	10 A	17 A	24 A	38 A	48 A	62 A	75 A	115 A
A	125	155	155	190	190	230	300	320	305	305
B	77	84	94	115	116	151	171	190	240	236
C	171	212	208	224	224	275	355	395	395	495
D	100	130	123	170	170	180	240	240	240	280
E	55	56	71.5	57.5	77.5	122	137	132	162	151
F	5x8	8x12	8x12	8x12	8x12	8x12	11x15	11x15	11x15	11x15
G	2.5 mm ²	2.5 mm ²	4 mm ²	4 mm ²	10 mm ²	10 mm ²	16 mm ²	35 mm ²	50 mm ²	50 mm ²
V	M3	M4	M4	M6	M6	M8	M8	M8	M8	M8

	180 A	260 A	410 A	480 A	660 A	750 A	880 A	1200 A
A	450	453	490	510	645	665	660	750
B	260	255	355	355	410	468	450	375
C	385	485	600	618	732	670	885	925
D	400	370	430	430	570	570	570	570
E	130	150	194	195	210	220	220	220
F	9x13	11x15	10.5x18.5	13x27	13x27	13x26	13x26	13x26
H	328	328	328	328	463	555	463	665
I	170	170	170	270	370	375	370	375
J	200	220	240	220	220	200	220	220
K	300 (150)	300 (150)	300 (150)	300 (150)	400 (200)	510 (255)		620 (310)
L	150	150	150	250	350	350	350	350
M	9	9	9	9	9	9	9	9
V	M10	M10	M10	M10	M10	M10	M10	M10
W	25	25	40	40	40	40	50	60
X	13/15	13/15	13/16	13/20	20	20	14	17
Y	21	20	25	23	40	40	22	26
Z	10.3	10.3	10.3	10.3	14	14	14	14

All dimensions in mm; 1 inch = 25.4 mm
Tolerances according to: ISO 2768-m / EN 22768-m

Mechanical data FN 5045

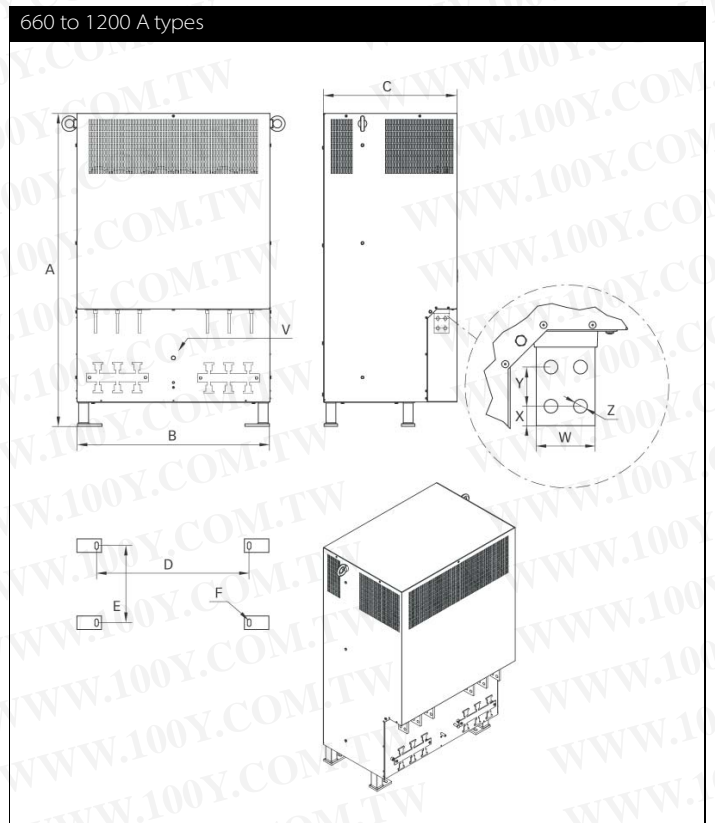
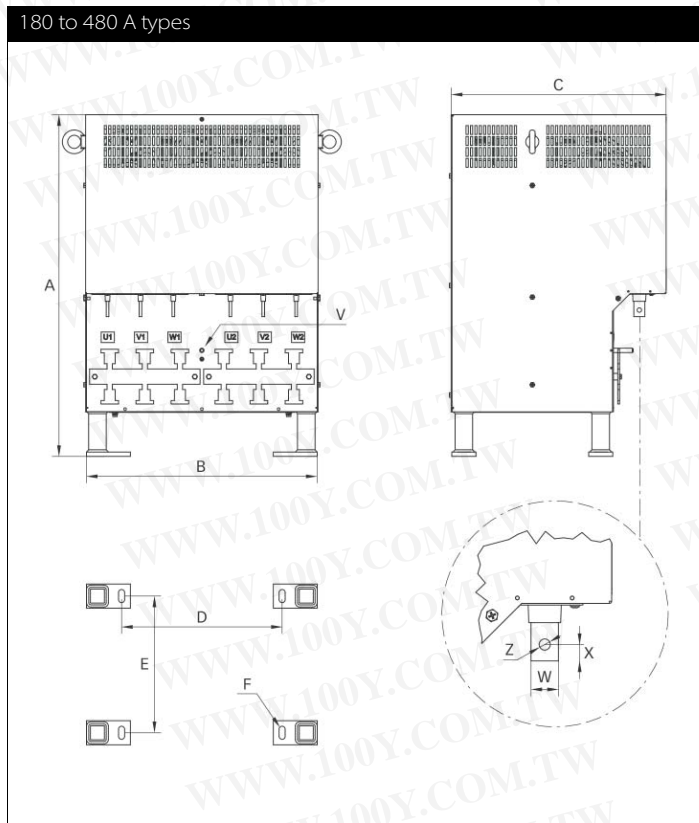
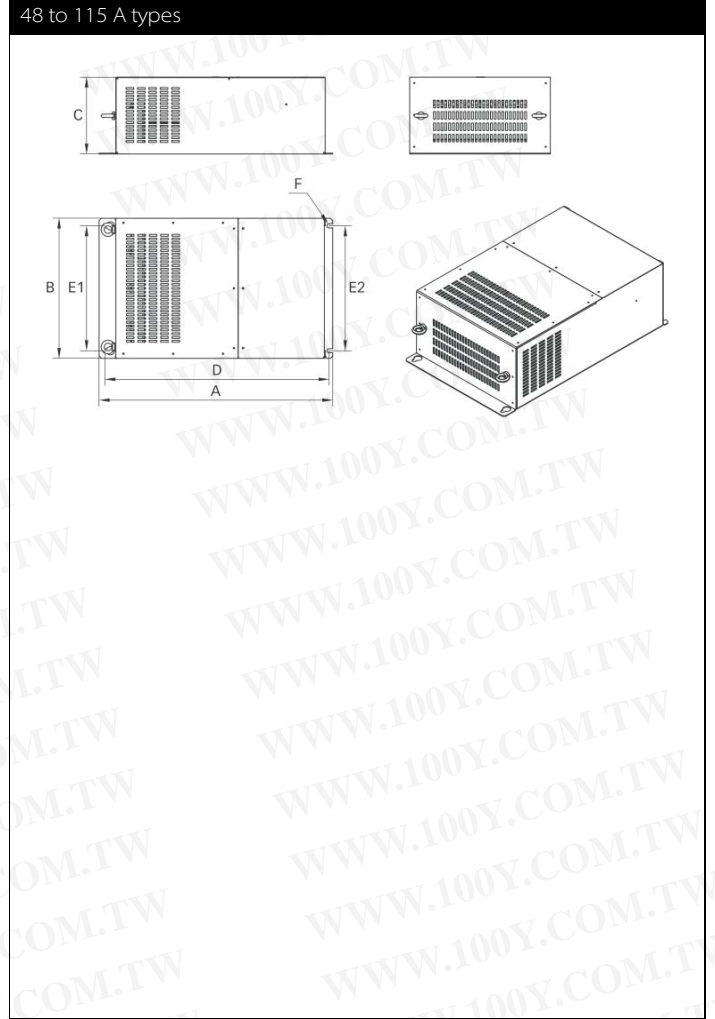
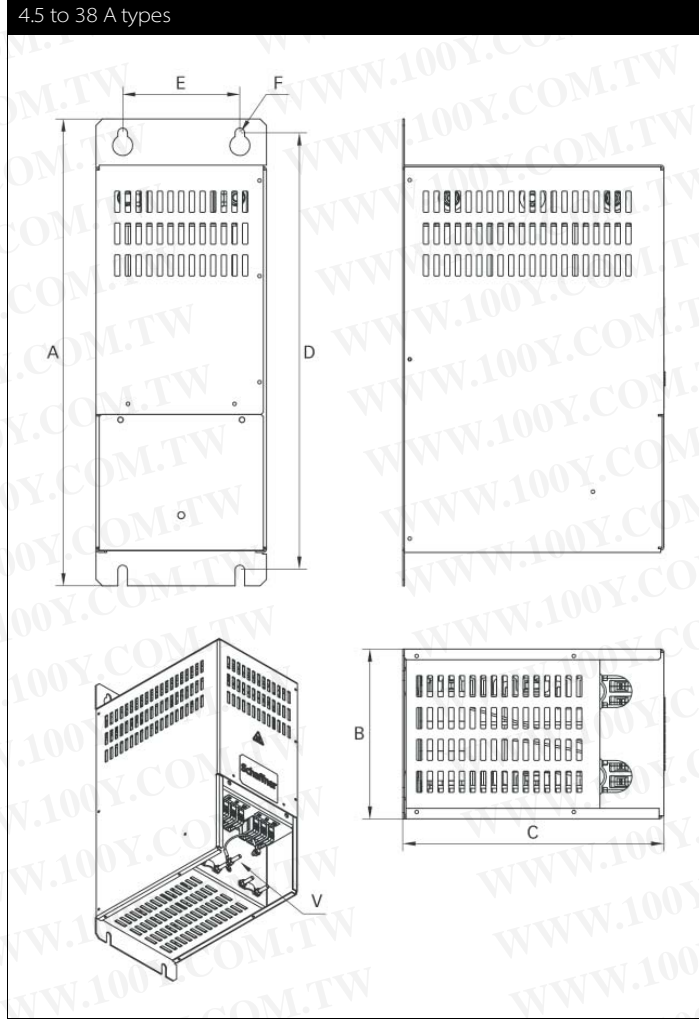

Dimensions FN 5045





	4.5 A	8 A	10 A	17 A	24 A	38 A	48 A	62 A	75 A	115 A	180 A	260 A	410 A	480 A	660 A	750 A	880 A	1200 A
A	330	330	330	440	440	440	515	515	615	615	650	650	780	780	1280	1280	1280	1280
B	100	100	100	160	160	160	320	320	370	370	508	508	538	538	794	794	794	794
C	165	165	165	245	245	245	153	153	203	203	400	400	494	494	498	498	550	550
D	310	310	310	412	412	412	488	488	590	590	336	336	336	336	622	622	622	622
E	60	60	60	110	110	110	280	280	330	330	243	243	312	312	315	315	315	315
F	7	7	7	9	9	9	9	9	11	11	14x30	14x30	14x30	14x30	14x30	14x30	14x30	14x30
J	M5	M5	M5	M5	M5	M5	M5	M5	M8	M8	M10	M10	M10	M10	M10	M10	M10	M10
W											20	20	25	40	40	40	40	60
X											15	15	15	15	20	20	20	20
Y															40	40	40	30/40
Z											9	9	10.2	10.2	14	14	14	14





All dimensions in mm; 1 inch = 25.4 mm

Tolerances according: ISO 2768-m / EN 22768-m

勝特力材料 886-3-5753170
 勝特力电子(上海) 86-21-34970699
 勝特力电子(深圳) 86-755-83298787
[Http://www.100y.com.tw](http://www.100y.com.tw)

Filter output connector cross sections

	-33	-34	-35	-44	-82
					
Solid wire	16 mm ²	35 mm ²	50 mm ²	10 mm ²	0.75 - 2.5 mm ²
Flex wire	10 mm ²	25 mm ²	50 mm ²	6 mm ²	1.0 - 2.5 mm ²
AWG type wire	AWG 6	AWG 2	AWG 1/0	AWG 8	AWG 18 - 12
Recommended torque	1.5-1.8 Nm	4.0-4.5 Nm	7-8 Nm	1.5-1.8 Nm	1.0-1.2 Nm

	-83	-84	-85	-86	-87
					
Solid wire	0.75-4.0 mm ²	2.5-10.0 mm ²	2.5-25.0 mm ²	0.75-50 mm ²	16.0-50.0 mm ²
Flex wire	1.0-4.0 mm ²	4.0-10.0 mm ²	4.0-16.0 mm ²	0.75-35 mm ²	25.0-50.0 mm ²
AWG type wire	AWG 18-10	AWG 18-6	AWG 22-4	AWG 18-0/1	AWG 6-0
Recommended torque	1.5-1.8 Nm	4.0-4.5 Nm	1.5-1.8 Nm	3.2-3.7 Nm	6.0-8.0 Nm

Please visit www.schaffner.com to find more details on filter connectors.